

ROLL PACKER

The Roll Packer effectively reduces the volume of waste, significantly lowering the number of costly transport operations – a 40 m³ container can hold approximately 10 tonnes of crushed wood. The machine is equipped with automatic lubrication at joints for trouble-free operation.



BENEFITS OF ROLL PACKER

MORE EFFICIENT USE OF TIME

Thanks to the automated process, less time is required for waste management, allowing more focus on core business activities.

SIMPLER AND SAFER

Compaction facilitates easy and comfortable material handling, contributing to a cleaner and safer working environment.

LOWER TRANSPORT COSTS

Compaction reduces waste volume which reduces transport for the disposal of dry mixed recycling or general waste. This therefore reduces CO₂ and costs associated with transport in equal measure.



WHY CHOOSE THE ROLL PACKER?

- Thoughtfully designed – robust compactors with long service life.
- Reliable and easy to maintain.
- High level of equipment included in the basic: automatic lubrication, automatic drum lift, and high arm.

ROLL PACKER

SPECIFICALLY DEVELOPED FOR BULKY WASTE

The Roll Packer is the solution for compacting large volumes of bulky waste. The machine offers top reliability and quality, backed by over 30 years of experience, setting the standard for durability and maintenance. Through the continuous rolling motion of the heavy packing drum, the material thrown in is broken down, torn apart, and compacted so that up to five times more waste can fit into a container.

THE ROLL PACKER IS IDEAL FOR:

- Bulky wood
- Furniture
- Metal
- Heavy-duty cardboard

WORKFLOW

1. The open container is filled with, for example, cable drums.
2. During operation, the roll crusher can be continuously refilled.
3. The specially equipped packing drum breaks, tears apart, and compacts the waste.
4. Result: compaction to a minimum of the original volume.

Technical Data and Standard Equipment of Static Roll Packer:







| | |
|----------------------------------------------------|---------------------------------|
| Power | 5.5 kW |
| Motor Speed | 1500 rpm |
| Voltage / Frequency | 380 – 415 V / 50 Hz |
| Power Supply Cable Specification | H07 RN-F |
| Plug Type | CEE 5 x 16A |
| User-Side Fuses | 3 x 25A |
| Control Voltage | 24 V |
| Protection Class | IP54 |
| Hydraulic Pumps | 11 / 8 / 8 cm ³ /rev |
| System Pressure | 220 bar |
| Hydraulic Oil Volume | 180 l |
| Hydraulic Oil Type | L-HV22 |
| Gear Oil Volume | 6 l |
| Gear Oil Type | VG 320 |
| Grease for Central Lubrication System | LT-43 |
| Designed for Containers with the Following Lengths | 5500 mm, 6000 mm, 6500 mm |
| Maximum Container Length | 6600 mm |
| Maximum Container Width | 2650 mm |
| Maximum Container Height | 3240 mm |
| Unit Weight | 3750 kg |

Our machines – roll packers

engines: 5.5 kW

cycle time: not considered

pressing force: not considered

| | Regular cardboard boxes | XXL cardboard boxes | Foil | Mixed waste | Very wet waste | Wood |
|--------------------------------------|-------------------------------------------------------------------------------------|-------------------------------------------------------------------------------------|-------------------------------------------------------------------------------------|-------------------------------------------------------------------------------------|---------------------------------------------------------------------------------------|---------------------------------------------------------------------------------------|
| Material (only handling to press) |  |  |  |  |  |  |

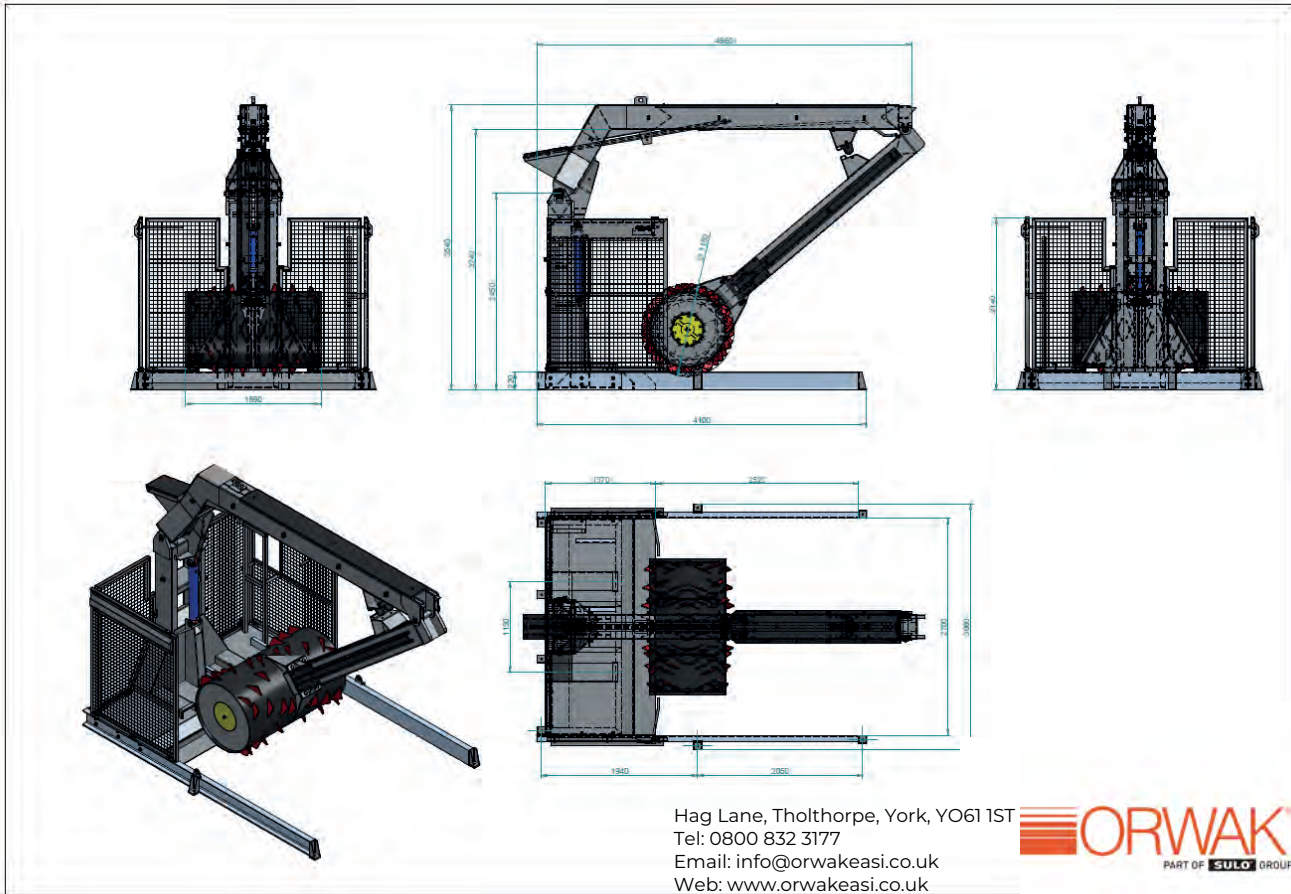
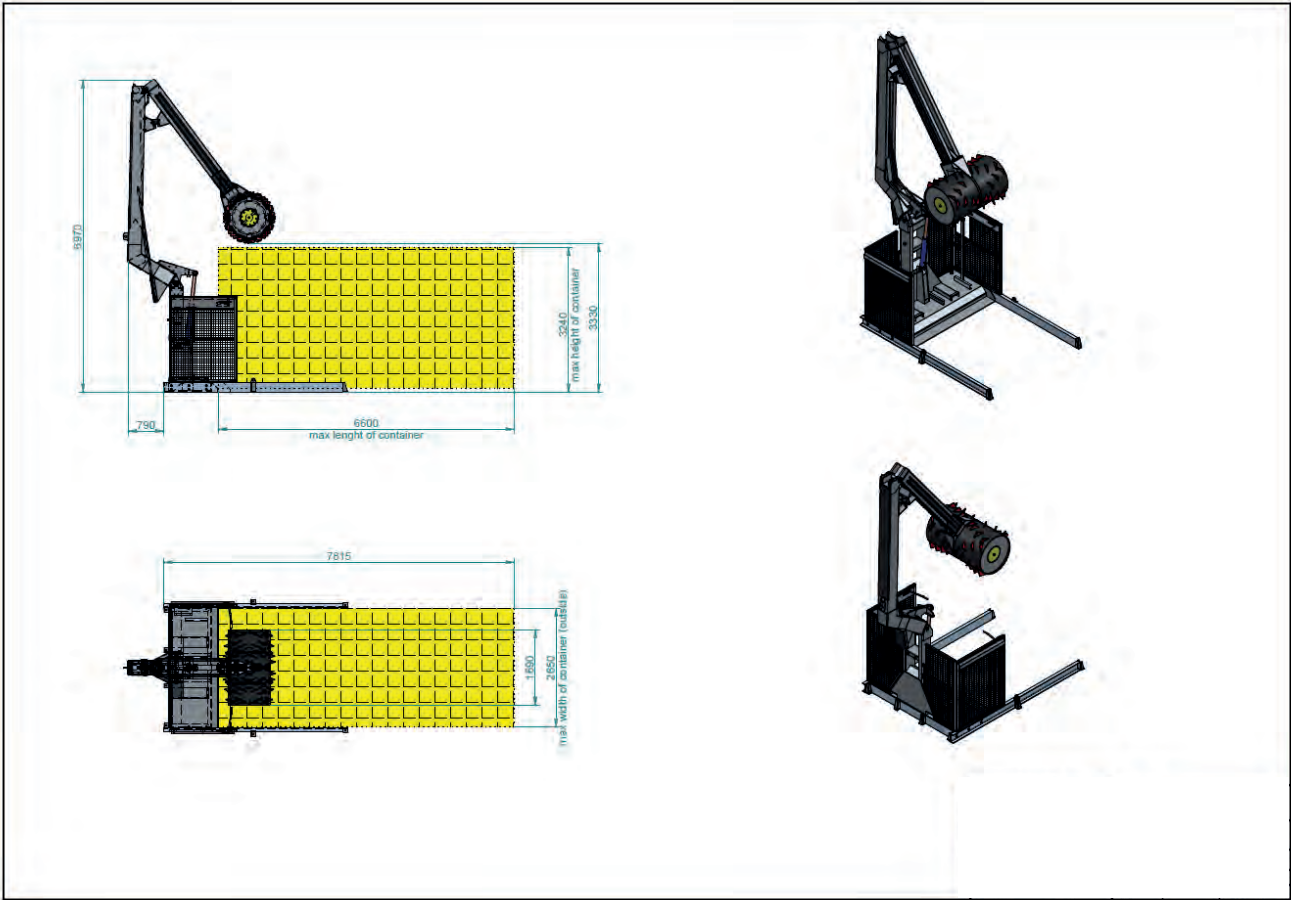

Hag Lane, Tholthorpe, York, YO61 1ST
 Tel: 0800 832 3177
 Email: info@orwakeasi.co.uk
 Web: www.orwakeasi.co.uk